

**ROPE COURSE STATION SPECIFICATIONS**

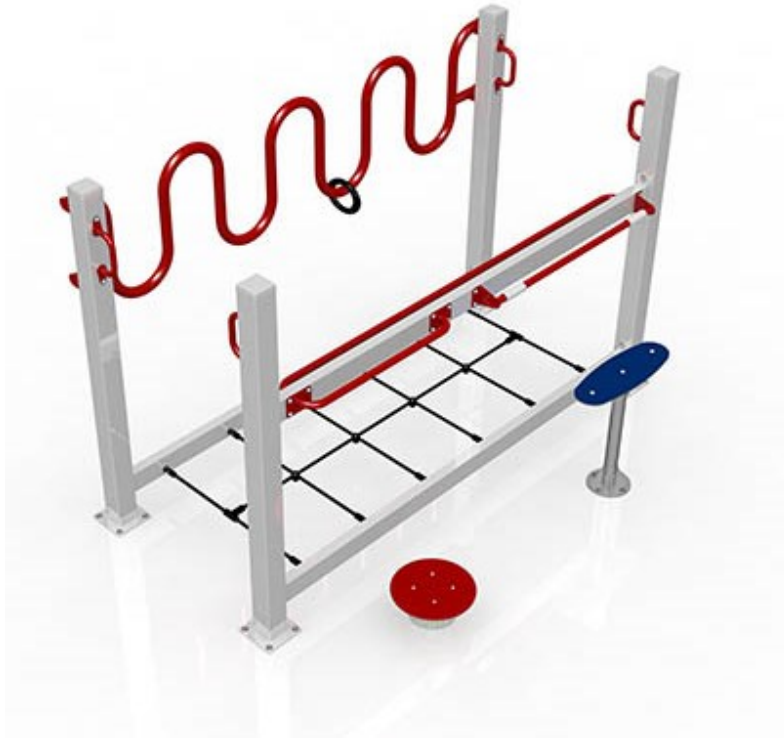

<b>Length:</b>	8'6" (2,60m)
<b>Width:</b>	5'10" (1,77m)
<b>Max Height:</b>	5'7" (1,69m)
<b>Recommended Work Zone:</b>	11'8" x 14'6" (3,55 x 4,43m)
<b>Product Equipment Dimensions:</b>	8'6" x 5'10" x 5'7" (2,60m x 1,77m x 1,69m)

Part #	Description
52570	ROPE NET FLOOR STATION STANDALONE SURFACE MOUNT
52566	ROPE NET FLOOR STATION ADD ON SURFACE MOUNT

**Component Specification-this system incorporates (5) fitness stations:**

1. Snake Bar
2. Rope Net Floor
3. Sitting Hand Throttle Bar
4. Balance & Hip Twist

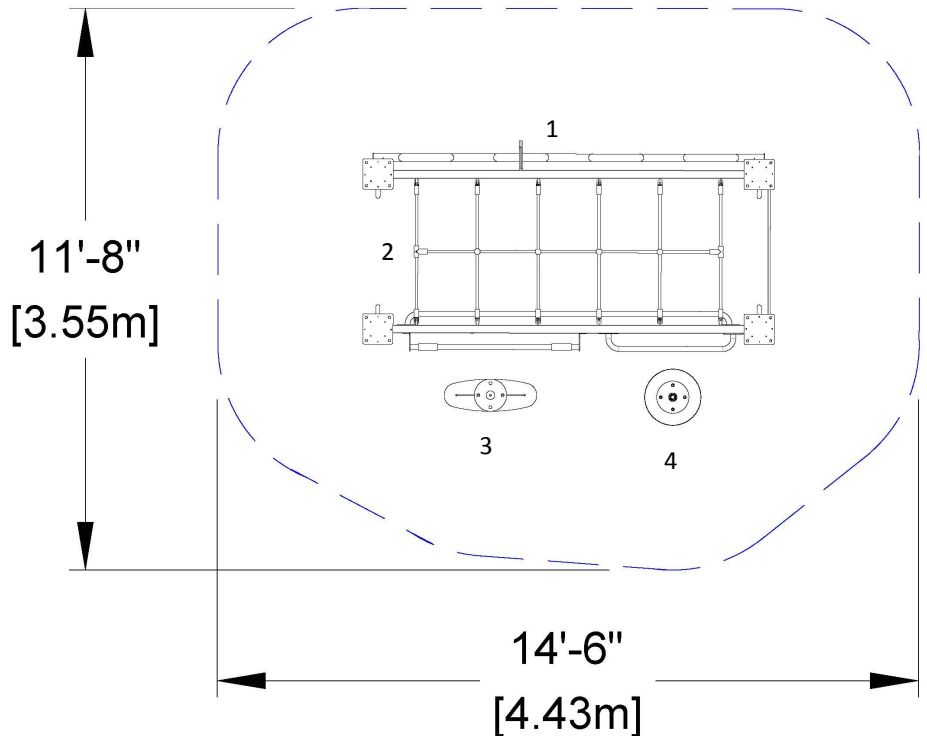

## ROPE COURSE STATION SPECIFICATIONS

### Senior Circuit System Specification (Design)

The Xccent Fitness Motion Wellness system is designed to create a functionally linked fitness oriented circuit system of low-medium-high degree of exercises that addresses the physical, cognitive, and socialization needed to perform everyday life activities.

**Physical Awareness:** There are several key fitness components that increase agility, balance, and coordination along with stretching joints and muscles. The enhancement of these skills will reduce the risk of falling.

**Cognitive Awareness:** Just as the body needs physical exercise to keep fit, the brain needs mental exercise to stay active and alive. Mental exercise stimulates the brain, often providing long-lasting positive effects regarding thinking and reasoning skills, memory and processing speed.

**Social Awareness:** Individuals have the ability to promote successful aging in many ways. Psychological or mental health can be maintained through positive attitudes toward adjustments to limitations and changes that may come with aging, continuing to seek intellectual stimulation by taking classes, socially interacting, and repeating brain stimulating exercises.

### Senior Circuit System Specification (Training)

Each Motion Wellness system comes with a training tutorial on the individual system on how to use each component in the system. The training tutorial will also explain the benefits that are achieved through exercise and repetitive use of the individual station.

### Senior Circuit System Specification (Research)

The Xccent Fitness Motion Wellness System has gone through a documented research analysis (see White Paper Documentation) of the fitness activities on the system to demonstrate how stations and accessories of the Motion Wellness System can help seniors' reduce the risk of falls. The Motion Wellness System improves stability, balance and coordination by using individually designed stations that have been shown in the medical research literature to reduce falls. The research was conducted by:

Carole B. Lewis, PT, DPT, GCS, GTC, CCOEE, MPA, MSG, PhD, FAPTA  
Editor-in-Chief, Topics in Geriatric Rehabilitation  
Adjunct Professor, George Washington University  
Department of Geriatrics, College of Medicine  
5343 43<sup>rd</sup> St. NW  
Washington, DC 20015  
[www.topicsingeriatricrehabilitation.com](http://www.topicsingeriatricrehabilitation.com)  
[www.greatseminaronline.com](http://www.greatseminaronline.com)

## ROPE COURSE STATION SPECIFICATIONS

### Material Specifications

**Snake Bar:** Zig Zag Pipe and Snake Pipe events are made from 1.90" O.D. x 14GA galvanized, A500 cold rolled steel, powder coated. Hand ring around Zig Zag Pipe and Snake Pipe events is made from High-Density Polyethylene (HDPE).

**Balance & Hip Twist:** One piece welded construction made of 12GA A1011 hot rolled steel and coated with UV stabilized PVC (plastisol). The PVC has an additional sprayed PVC texture called "X-tuff" coating increasing foot traction and support.

**Sitting Hand Throttle Bar:** Railings and other metal exercise and support components are made from 1.25" O.D. 12GA galvanized, A500 cold rolled steel, powder coated.

**Rope Net Floor:** The ropes are tested by TÜV and are approved for outdoor recreation building according to the standards of EN1176. The rope is made of six-strand galvanized steel wire 0.8mm covered with Polypropylene multifilament. The core (fibre core) is made of Polypropylene. Color is UV protected. Not toxic material or color is used in production. Rope Dimension: 16mm, weight 270g/m, break load 40,0kN. Rectangle steel frame that supports walking rope exercises are constructed of 2.0" x 4.0" 11ga. galvanized, A500 cold rolled steel, powder coated.

**Step:** One piece welded construction made of 12GA A1011 hot rolled steel and coated with UV stabilized PVC (plastisol). The PVC has an additional sprayed PVC texture called "X-tuff" coating increasing foot traction and support.

**Posts:** Square steel tube posts are 4.0" x 4.0" 11GA galvanized, A500 cold rolled steel, powder coated.

**Handrails:** Railings and other metal exercise and support components are made from 1.25" O.D. 12GA galvanized, A500 cold rolled steel, powder coated.

**Signage:** Each fitness component/exercise on the circuit system comes with proper signage to explain the use and benefit of the exercise. Each individual signage board is 3.50" x 6.00" and 3mm thick, high-pressure laminate (HPL).

**Hardware/Fasteners:** Stainless steel button head torx tamper resistant shall be corrosion resistant, and pre-treated with a locking/sealing adhesive. Non stainless steel hardware shall be zinc plated grade 5 steel.

**PVC Coating (Poly-Vinyl Chloride):** Prior to the application of PVC, all parts are cleaned with a state-of-the-art 6-stage wash system which utilizes environmentally safe chemicals and Nanotechnology to provide excellent corrosion resistance and paint adhesion when compared to traditional iron phosphate pretreatment systems. Once parts have passed through a dry off oven, a proprietary heat activated primer is applied. Xccent Fitness works with suppliers to ensure primer is formulated to molecularly bond with the PVC formulation and provide superior adhesion to the metal substrate. Once the primer has dried, each part is pre-heated to a temperature no less than 350° F and submerged into liquid PVC. Surfaces shall have coating thickness of .085-.150 in.

**IMPORTANT NOTE:** *PVC shall comply with the Consumer Product Safety Improvement act of 2008 by having a concentration that does not exceed 0.1% of the following phthalates; DINP, DIDP, DnOP, DEHP, or BBP. This formulation is also free of heavy metals such as Lead and Cadmium.*

**The PVC physical properties shall have no less than:**

- Tensile strength of no less than 1500 psi per ASTM 412.
- Elongation of no less than 300% min per ASTM 412.
- Tear strength of no less than 250 lb./in. per ASTM 624.
- Hardness of 70 +/- 5 (Durometer, Shore A) per ASTM 2240.
- PVC formulated to withstand the requirements of outdoor UV exposure.
- The material will meet or exceed the requirements of the Federal Safety Standard MVSS 302 and UL 94 HB requirements.

## ROPE COURSE STATION SPECIFICATIONS

**Xccent Fitness' Ultra Durable Two-Part Powder Coating Process:** Prior to the application of Xccent Fitness' proprietary marine grade epoxy primer, all parts are cleaned with a state-of-the-art 6-stage wash system that utilizes environmentally safe chemicals and Nanotechnology to provide excellent corrosion resistance and paint adhesion when compared to traditional iron phosphate pretreatment systems. Parts are then dried using a forced air dry off oven set at 380° F to ensure all moisture is removed.

- **Primer Application:** A minimum of 3 mil's of Xccent Fitness' proprietary marine grade primer is applied to ensure superior protection against corrosion caused by the most extreme environments. Once the primer has been applied it is ran through a pass through oven to pre-cure the primer which will allow the primer to interlock with the top coat (color) when applied. This process allows for superior adhesion and durability.
- **Marine Grade Primer Physical Properties:** Resistance to Humidity: No more than 1/32" undercutting and no blistering in 1000 hours (humidity test per ASTM D2247). Resistance to Salt Spray: No more than 1/32" undercutting and no blistering in 3000 hours (salt spray test per ASTM B117).
- **Ultra Durable Powder Coating (Top Coat Color):** Xccent Fitness uses an Ultra Durable polyester/TGIC powder coating with superior color-, gloss-, and UV-stabilizing qualities ideal for exterior applications. The coating shall be 2.5 – 3.5 mils minimum and cured in an oven at temperatures no less than 338° F and no more than 395° F. Xccent Fitness' powder coating process ensures that each product will meet or exceed the following physical properties:

Physical Property	Test Method	Value
Gloss	ASTM D-523	50-100 @ 60°
Adhesion	ASTM D-3359	100% (5B Pass)
Hardness	ASTM D-3363	H-2H Pencil (Eagle)
Impact resistance	ASTM D-2794	40 – 160 In.-lbs Direct
Conical Mandrel	ASTM D – 522	1/8" Mandrel – No Cracking
Salt Spray	ASTM B-117	1000 Hrs. Pass < 1/32" Scribe Creep No Blisters
Humidity	ASTM D – 1735	1000 Hrs. Pass < 1/32" Scribe Creep No Blisters

Xccent Fitness' two-part primer and powder coating system provides superior color, gloss and UV stabilizing properties, excellent mar and chip resistance, good chemical resistance, along with excellent corrosion protection for exterior use.

**\* Contact Xccent Fitness or visit [xccentfitness.com](http://xccentfitness.com) for warranty information.**